



DIY miniature safety edges



EN | Product information

Mayser GmbH & Co. KG

Örlinger Strasse 1-3

89073 Ulm

GERMANY

Tel.: +49 731 2061-0

Fax: +49 731 2061-222

E-mail: info.ulm@mayser.com

Website: www.mayser.com

Table of contents

Overview	3
Materials list.....	4
Definitions	5
Pressure-sensitive protective device	5
Operation principle of 2-wire-technology	6
Operation principle of 4-wire-technology	7
Safety.....	8
Intended use	8
Limits	9
Exclusions	9
Other safety aspects	9
Design	10
Effective actuation area	10
Installation position	11
Connection	11
Cable exits	11
Cable connection	11
Wire colours.....	12
Connection examples	12
Sensor surface.....	13
Resistance	13
Fixing.....	15
Using acrylic foam adhesive tape.....	15
Using a snap-in foot.....	16
Using a clamp foot.....	16
Maintenance and cleaning.....	17
Technical data.....	18
SK EKS 011 TPE.....	18
SK EKS 014 TPE.....	19
SK EKS 052 TPE.....	20
Marking	21
UL certification.....	21

Copyright

The reproduction, distribution and utilisation of this document as well as the communication of its contents without express authorisation is prohibited. Offenders will be held liable for the payment of damages. All rights reserved in the event of the grant of a patent, utility model or design.

© Mayser Ulm 2025

Overview

Contact profile – miniature safety edge

The semi-finished contact profile is cut to length and assembled with the other components to create the finished working product, which is called a miniature safety edge.

EKS 011 TPE

- 1 End piece with resistor
- 2 Contact profile
- 3 End piece with cable

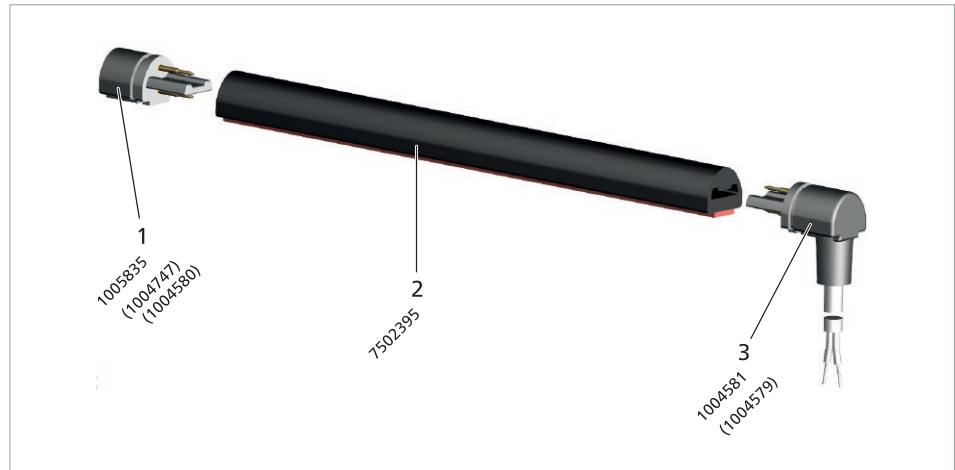

EKS 014 TPE

- 1 End piece with resistor
- 2 Contact profile
- 3 Aluminium profile
- 4 End piece with cable

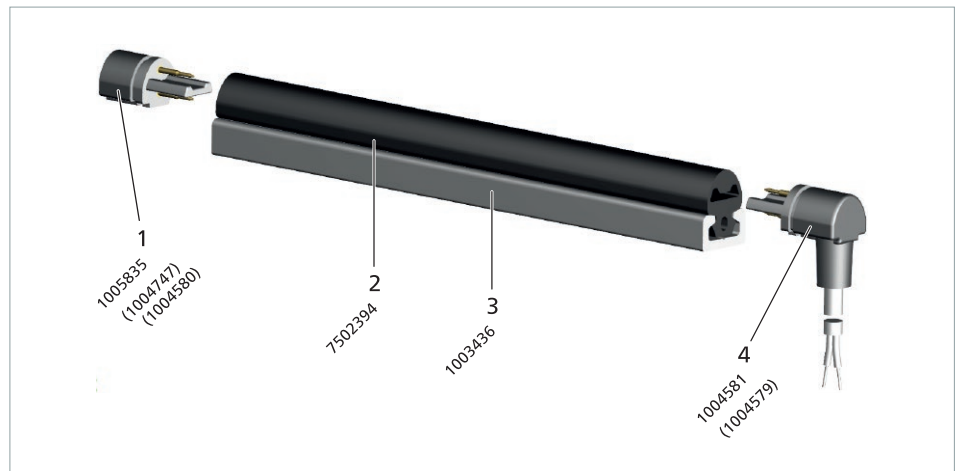

EKS 052 TPE

- 1 End piece with resistor
- 2 Contact profile
- 3 End piece with cable

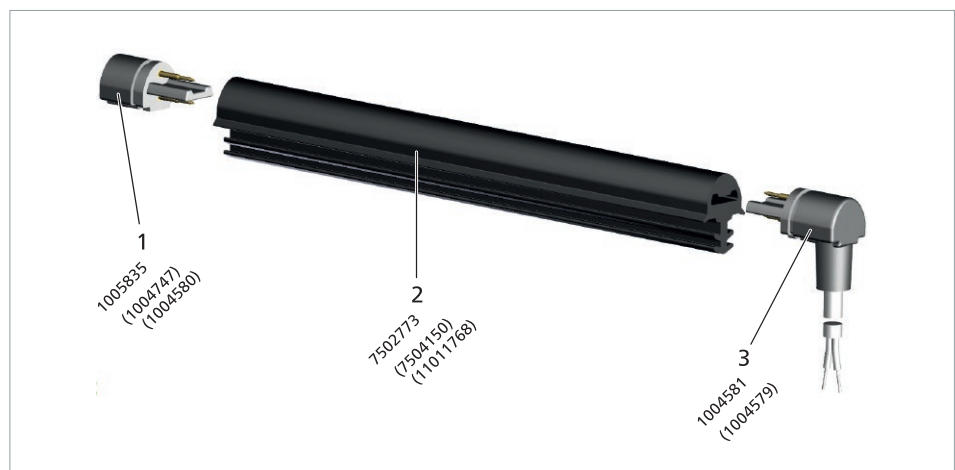

Subject to technical modifications.

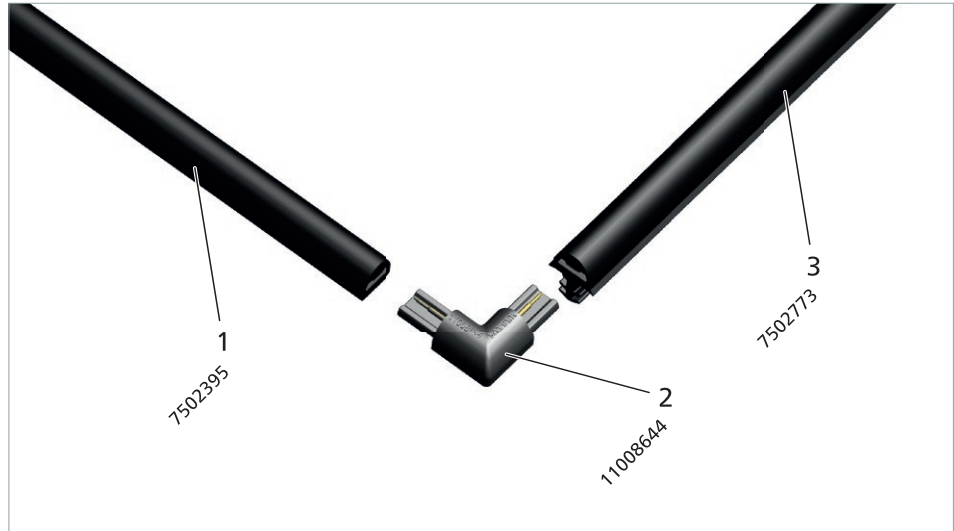

Example combination comprising:

- 1 Contact profile EKS 011
- 2 Connector
- 3 Contact profile EKS 052

Materials list

Part No.	Designation	PU
7502395	Contact profile EKS 011 TPE, self-adhesive	50 m (164')
7502394	Contact profile EKS 014 TPE, with snap-in foot	50 m (164')
7502773	Contact profile EKS 052 TPE, with clamp foot, black	45 m (147')
7504150	Contact profile EKS 052 TPE, with clamp foot, window grey *	45 m (147')
11011768	Contact profile EKS 052 TPE, with clamp foot, light grey *	45 m (147')
1004580	End piece with resistor 1k2	50 pcs.
1004747	End piece with resistor 2k2	50 pcs.
11008731	End piece with resistor 5k6 *	50 pcs.
1005835	End piece with resistor 8k2	50 pcs.
1004579	End piece with PVC cable 2.5 m (8'), axial	50 pcs.
1004581	End piece with PVC cable 2.5 m (8'), angled 90°	50 pcs.
11008644	90° connector * incl. assembly aid SH4	50 pcs.
1007219	End piece without resistor *	50 pcs.
1003436	Aluminium profile C 10 for EKS 014 with snap-in foot	6 m (19' 8")
11002568	Scissors with stop	1 pc.
11012760	Assembly aid SH4	1 pc.
11013001	Installation instructions for DIY miniature safety edges	1 pc.

* Not covered by UL certification

Definitions

Pressure-sensitive protective device

A pressure-sensitive protective device consists of one or more pressure-sensitive sensors, a signal processing unit, and one or more output signal switching devices. The control unit is made up of the signal processing unit and output signal switching device(s). The pressure-sensitive protective device is triggered when the sensor is activated.

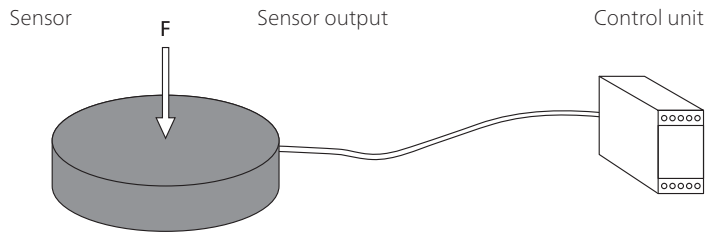

Sensor

The sensor is the part of the pressure-sensitive protective device that generates a signal when the actuation force F is applied. Mayser safety systems feature a sensor whose actuation area is deformed locally.

Signal processing

The signal processing unit is the part of the pressure-sensitive protective device that converts the output signal of the sensor and controls the status of the output signal switching device. The output signal switching device is the part of the signal processing unit which is connected to the downstream control system and which transmits safety output signals such as STOP.

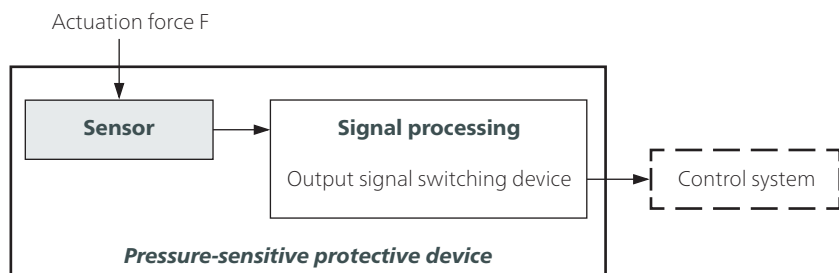

Tip: Terms are defined in ISO 13856-2 Section 3.

Tip: Safety-related terms are defined in ISO 13849-1 Section 3.

Criteria for selecting the sensor type

- Category according to ISO 13849-1
- Performance level (PL) of the pressure-sensitive protective device = at least PL_r
- Temperature range
- Degree of protection according to IEC 60529:
IP40 is the standard for DIY miniature safety edges.
Higher degrees of protection are possible if special adhesive is used.
- Low actuation forces
- Minimum overall height
- Small bend radii; 90° angles possible with 90° connector (part no. 11008644)

Operation principle of 2-wire technology

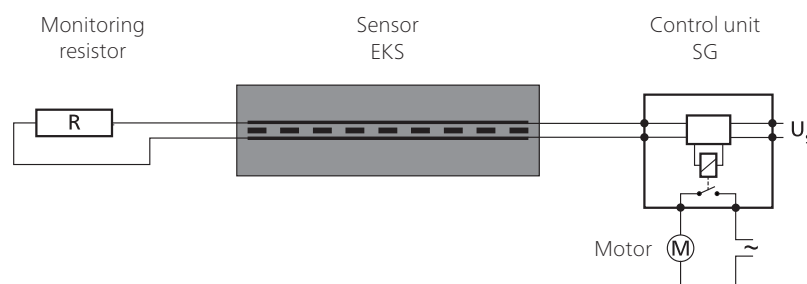

The monitoring resistor must be compatible with the control unit. The standard type is 8k2.

For your safety:

The sensor and connection cables are constantly monitored to ensure they are functioning correctly. Monitoring relies on controlled bridging of the contact surfaces with a monitoring resistor (closed-circuit principle).

Types

/BK With cables on both sides for use as a through sensor or with an external monitoring resistor for use as an end sensor

/W With an integrated monitoring resistor for use as an end sensor

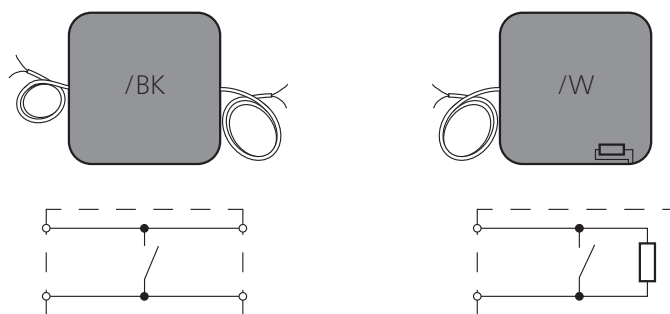

Sensor combination

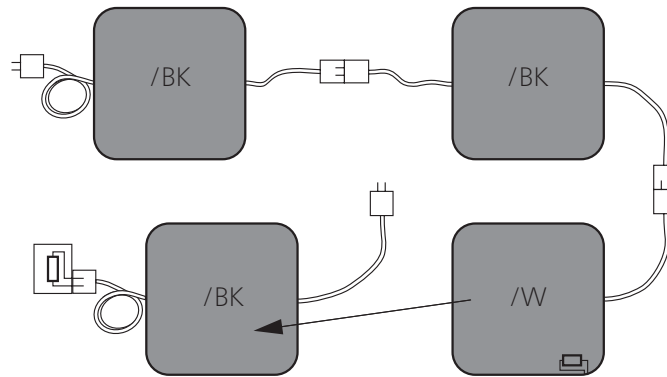

Version with external resistor, therefore no variety of models

Combination:

- Connection of more than one sensor
- Only one control unit required
- Safety edges can be combined to achieve custom lengths and angles

Operation principle of 4-wire technology

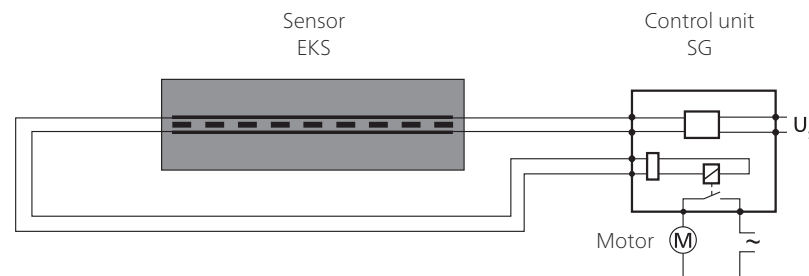

The 4-wire technology can only be used together with control unit SG-EFS 104/4L.

For your safety:

The sensor and connection cables are constantly monitored to ensure they are functioning correctly. Monitoring relies on signal transmission feedback – without a monitoring resistor.

Types

/BK With cables on both sides for use as a through sensor



Sensor combination

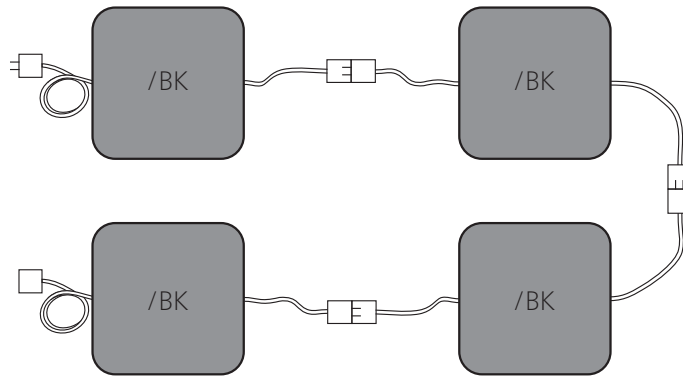

Combination:

- Connection of more than one sensor
- Only one control unit required
- Safety edges can be combined to achieve custom lengths and angles

Safety

Intended use

A miniature safety edge detects a person or part of their body when pressure is applied to the actuation area. It is a linear tripping device. Its purpose is to prevent possible hazardous situations that could affect someone within a danger zone, such as shearing and pinching edges.

Typical areas of application are automated windows and façade systems, automation technology and moving units in medical technology.

Safe operation of a miniature safety edge depends entirely on

- the surface condition of the mounting surface,
- the correct choice of EKS profile and
- correct installation.

Due to the design, the actuation area is actually smaller than it looks because of the non-sensitive edges. Once these have been allowed for, what remains is the effective actuation area (see chapter *Effective actuation area*).

Limits

- No more than 3 /BK-type sensors can be connected to one control unit
- No more than 2 /BK-type sensors and 1 /W-type sensor can be connected to one control unit

If more sensors are required, please contact Mayser's service department.

Note: Two contact profiles connected via a 90° connector count as 2 sensors.

Exclusions

The sensors are **not** suitable for:

- Performing a sealing function. Constant actuation of sensors can result in permanent damage.

Other safety aspects

The following safety aspects relate to pressure-sensitive protective devices consisting of a sensor and a control unit.

Performance Level (PL)

Fault exclusion according to ISO 13849-2 Table D.8: Non-closing of contacts in the case of pressure-sensitive protective devices according to ISO 13856. In this case, the diagnostic coverage (DC) is not calculated or taken into account when determining the PL. Assuming a high $MTTF_D$ value for the control unit, a performance level of up to PL d can be achieved by the pressure-sensitive protective device.

Is the protective device suitable?

First, the integrator must decide what PL_r is required for the hazard. After that, they must select the protective device.

Finally, the integrator needs to check whether the category and PL of the selected protective device are appropriate.

Risk and safety assessment

For the risk and safety assessment of your machine, we recommend ISO 12100 "Safety of machinery — General principles for design".

Without reset function

When a protective device without reset function is used (automatic reset), the reset function must be provided in some other way.

Design

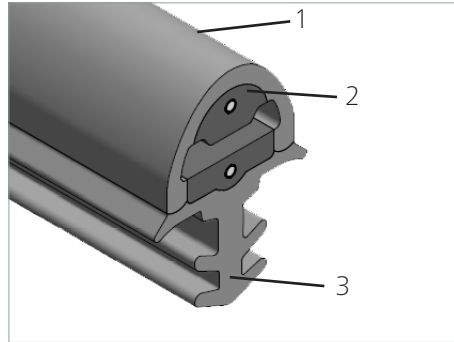

The miniature safety edge consists of a sensor (1 to 3)
 (1) EKS contact profile with
 (2) integrated NO switch element,
 (3) mounting element
 and an SG evaluating control unit.

Effective actuation area

The parameters X, Y, Z, L_{WB} and the angle α describe the effective actuation area. For the effective actuation area, the following applies:

$$L_{WB} = L_{EKS} - 2 \times L_{NE}$$

Parameters:

- L_{WB} = effective actuation length
- L_{EKS} = overall length of the miniature safety edge
- L_{NE} = non-sensitive length at the end of the miniature safety edge
- α = effective actuation angle

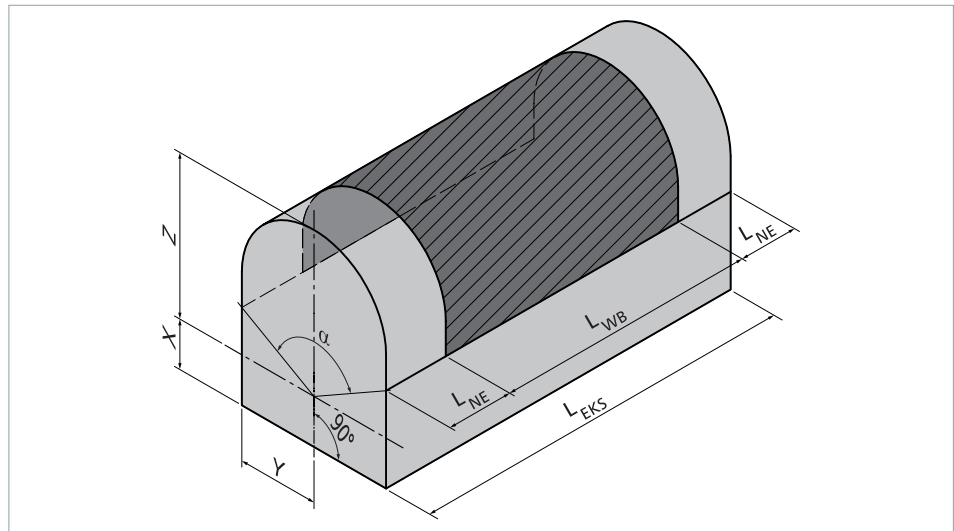

All dimensions are in millimeter (mm), unless otherwise stated.

		EKS 011	EKS 014	EKS 052
α		80°	80°	80°
L_{NE}	End piece W	27 (1 1/16")	27 (1 1/16")	27 (1 1/16")
	End piece with cable, axial	27 (1 1/16")	27 (1 1/16")	27 (1 1/16")
	End piece with cable, angled 90°	28.5 (1 1/8")	28.5 (1 1/8")	28.5 (1 1/8")
	90° connector	27 (1 1/16")	27 (1 1/16")	27 (1 1/16")
X	2.05 (5/64")	2.3 (3/32")	2.1 (5/64")	
Y	3.95 (5/32")	3.9 (5/32")	4.7 (3/16")	
Z	4.6 (3/16")	4.5 (11/64")	4.5 (11/64")	
X + Z	6.65 (17/64")	6.8 (17/64")	6.6 (17/64")	

Subject to technical modifications.

Installation position

The installation position can be selected as required, i.e. all installation positions from A to D as per ISO 13856-2 are possible.

Connection

Cable exits

Two cable exits are available: axial and angled 90°.

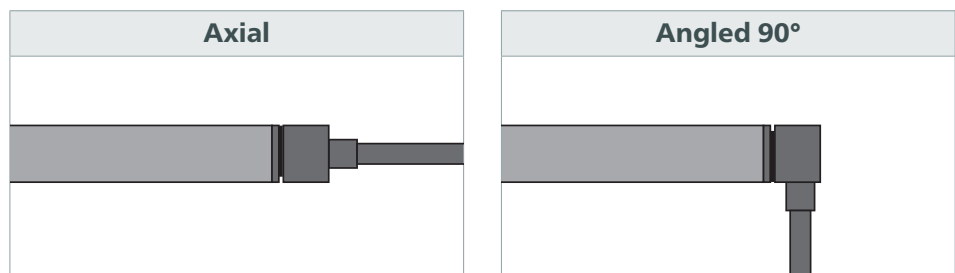

Cable connection

- Standard cable lengths
L = 2.5 m (8')
- Maximum total cable length to the control unit
 $L_{\text{max}} = 100 \text{ m (328')} \text{ (minus the lengths of the sensors)}$

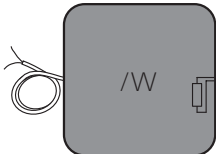
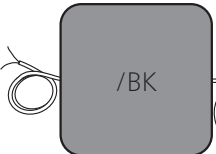
/W-type sensor with 1 line	/BK-type sensor with 2 lines
<ul style="list-style-type: none"> • As an individual /W-type sensor or a /W-type end sensor • Integrated resistor • 1 two-wire cable 	<ul style="list-style-type: none"> • As a /BK-type through sensor • Without resistor • 2 two-wire cables
	

Wire colours

Colour coding

BK Black
RD Red

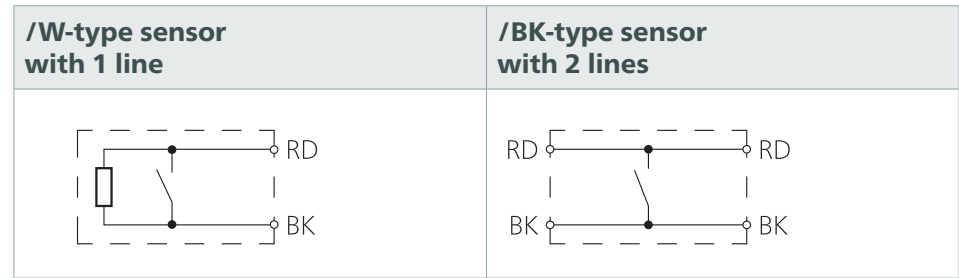

Connection examples

Key:

/W8k2 Sensor for 2-wire technology with resistor 8k2
/BK Sensor for 4-wire technology
M Motor

Colour coding

BK Black
RD Red

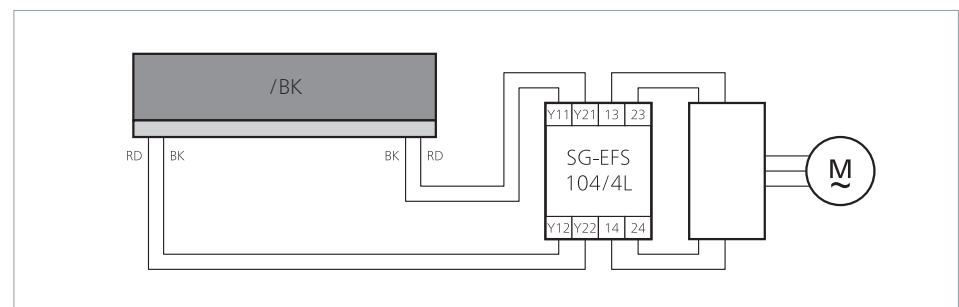
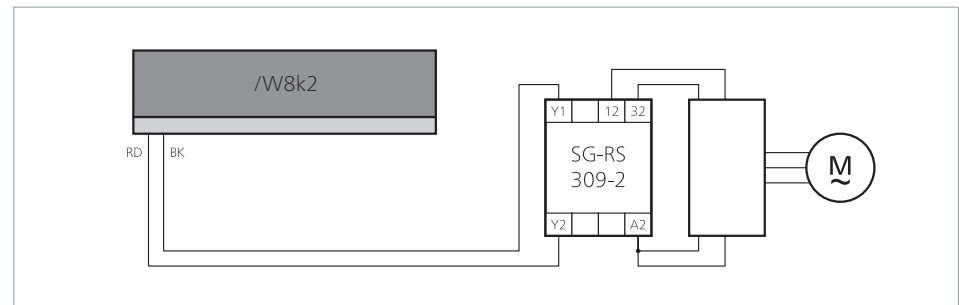
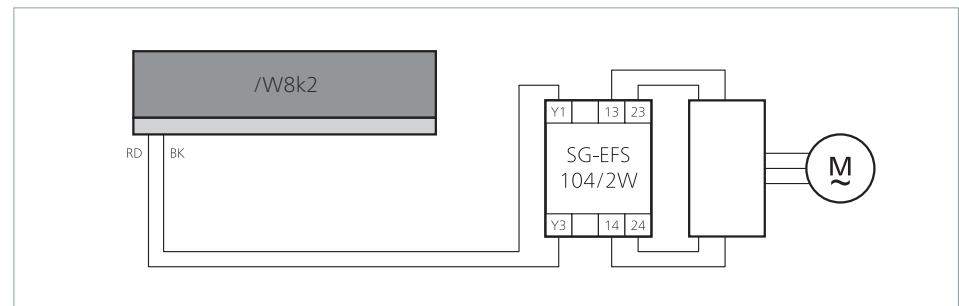

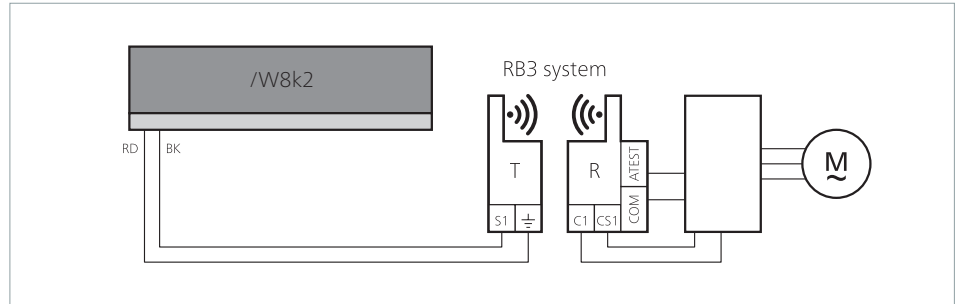

Sensor surface

Resistance

The resistance ratings listed below (at a room temperature of 23 °C (73.4 °F)) depend on the sensor having an undamaged surface.

Physical resistance

Higher degree of protection

Higher degrees of protection up to IP64 are possible using special adhesive (part no. 1004987).

	TPE
IEC 60529: degree of protection	IP40
UV resistance	Yes

Chemical resistance

The sensor is resistant to a certain extent to normal chemical influences such as diluted acids and alkalis, as well as alcohol, over an exposure period of 24 hours.

The values in the table are the results of tests carried out in our laboratory. You must always conduct your own practical tests to verify that our products are suitable for your specific area of application.

**Explanation
of symbols:**

- + = resistant
- ± = resistant to a certain extent
- = not resistant

	TPE
Acetone	-
Formic acid	-
Armor All	+
Car shampoo	+
Petrol	-
Brake fluid	+
Buraton	+
Butanol	-
Sodium hypochlorite	-
Disinfectant 1%	+
Diesel	-
Acetic acid 10%	-
Ethanol	+
Ethyl acetate	-
Ethylene glycol	+
Greases	±
Anti-frost agent	+
Skin cream	+
Incidin	+
Incidin Plus	+
Cooling lubricant	-
Plastic cleaner	+
Lyso FD 10	+
Metal working oil	-
Microbac	+
Microbac forte	+
Minutil	+
Saline solution 5%	+
Spirit (ethyl alcohol)	+
Terralin	+
Centring oil	-

Fixing

Three fixing methods are available:

- Using acrylic foam adhesive tape
- Using a snap-in foot
- Using a clamp foot

The fixing method depends on which contact profile is selected.

Fixing method	EKS 011	EKS 014	EKS 052
Acrylic foam adhesive tape	●	–	–
Snap-in foot	–	●	–
Clamp foot	–	–	●

Using acrylic foam adhesive tape

Double-sided foam adhesive tape is applied to the miniature safety edge. The double-sided foam adhesive tape (acrylic foam) is already affixed to the bottom side of the contact profile.

With primer

The clean, dry and smooth bonding surface must be treated with primer before sticking on the miniature safety edge.

Without primer

The only material that the acrylic foam will adhere to reliably without using primer is uncoated aluminium.

Not suitable

The following materials are not suitable for acrylic foam adhesive tape: CAB, glass, uncoated wood, PE, HDPE and PS.

Using a snap-in foot

The miniature safety edge is clipped into an aluminium profile.

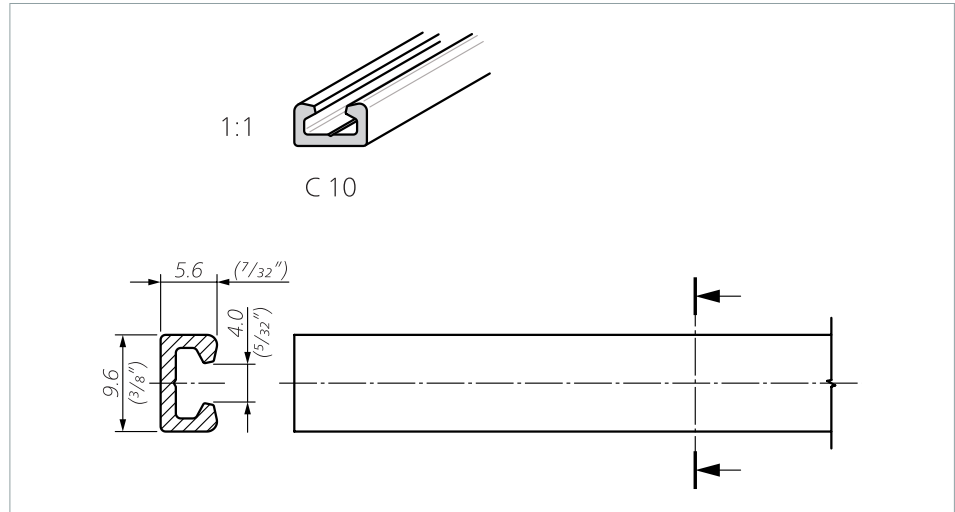

Tolerances in accordance with EN 755-9

Aluminium profile C 10

Standard profile for EKS 014:

First the aluminium profile must be mounted onto the closing edge and then the miniature safety edge clipped into the aluminium profile.

Using a clamp foot

The miniature safety edge is pressed into a groove. A precise groove ensures an accurate and lasting fit.

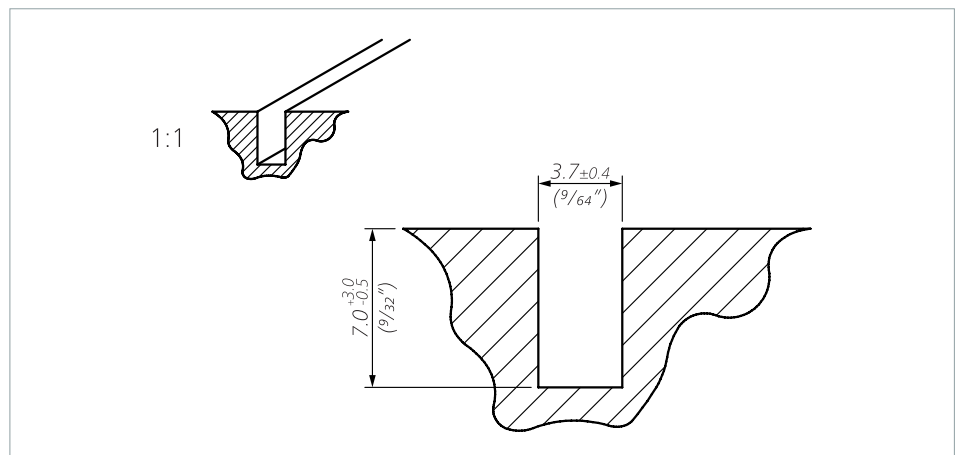

Maintenance and cleaning

The sensors are virtually maintenance-free.
The control unit also monitors the sensor at the same time.

Regular inspection

Depending on the operational demands, the sensors must be inspected at regular intervals (at least monthly)

- for proper functioning,
- for damage and
- for correct fixing.

Cleaning

If the sensors become dirty, they can be cleaned with a mild cleaning product.

Technical data

SK EKS 011 TPE

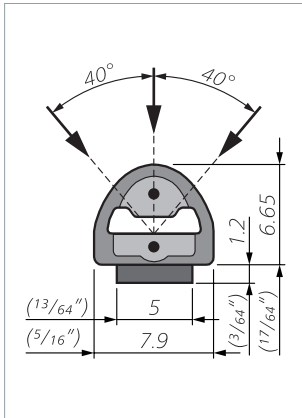

Dimensions in millimetres (mm)
Dimensional tolerances according to ISO 3302 E2/L2

Bend radii:

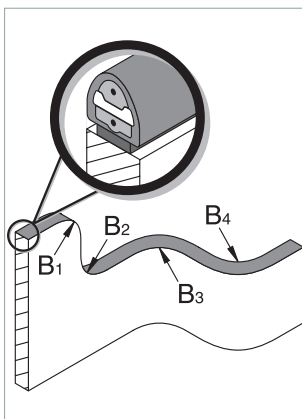

Higher degree of protection, higher tensile load

If special adhesive is used (e.g. Weicon VA 250 Black ID 10018873), higher degrees of protection of up to IP64 can be achieved and a tensile load of up to 60 N (13 lbf) can be exerted on the cable.

Miniature safety edge (without control unit)	SK EKS/W 011 TPE or SK EKS/BK 011 TPE
Testing basis	In accordance with ISO 13856-2
Sensor colour	Black
Switching characteristics at $v_{test} = 50 \text{ mm/min}$ (2 in/min)	
Switching operations	10,000
Actuation force	+23 °C (+73.4 °F) -25 °C (-13 °F)
Test piece (rod) Ø 4 mm (5/32")	< 15 N (3.3 lbf) < 30 N (6.7 lbf)
Test piece (rod) Ø 200 mm (7 7/8")	< 25 N (5.6 lbf) < 50 N (11.2 lbf)
Actuation distance	
Test piece (cylinder) Ø 80 mm (3 5/32")	< 2.0 mm (5/64")
Actuation angle	
Test piece (cylinder) Ø 80 mm (3 5/32")	±40°
Finger detection	Yes
Safety classifications	
ISO 13849-1: B _{10D}	2x 10 ⁶
Mechanical operating conditions	
Sensor length (min. max.)	10 cm 50 m (4" 164')
Cable length	2.5 m (8')
Fixing method	Acrylic foam adhesive tape
Peel force	15 N/cm (1.03 lbf/ft)
Bend radii, minimum: B ₁ B ₂ B ₃ B ₄	120 150 20 20 mm (4 23/32" 5 29/32" 25/32" 25/32")
Max. load capacity (impulse)	600 N (134 lbf)
Tensile load, cable (max.)	20 N (4 lbf)
IEC 60529: degree of protection	IP40
Operating temperature	-25 to +80 °C (-13 to +176 °F)
Short-term (15 min)	-40 to +100 °C (-40 to +212 °F)
Storage temperature	-40 to +80 °C (-40 to +176 °F)
Weight (with acrylic foam)	43 g/m (0.47 oz/ft)
Electrical operating conditions	
Terminal resistance (±1%)	1k2, 2k2, 5k6 or 8k2
Nominal output (max.)	250 mW
Resistance: sensor activated	< 400 ohms
Number of /BK-type sensors	Max. 3 in series
Switching voltage (max.)	DC 24 V
Switching current (min. max.)	1 10 mA
Connection cable	Ø 2.9 mm PVC 2x 0.25 mm ² (Ø 7/64" PVC 2x AWG24)

Technical data

SK EKS 014 TPE

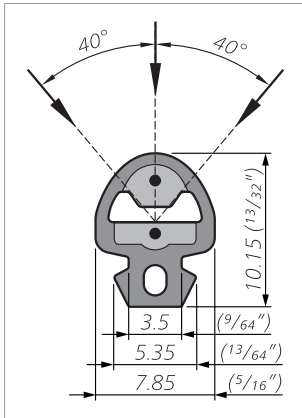

Dimensions in millimetres (mm)
Dimensional tolerances according to ISO 3302 E2/L2

Bend radii:

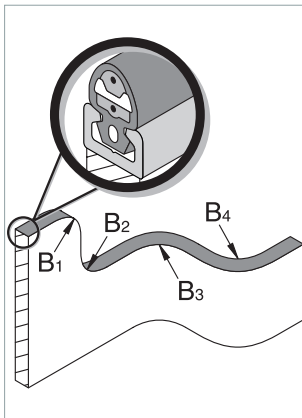

Higher degree of protection, higher tensile load

If special adhesive is used (e.g. Weicon VA 250 Black ID 10018873), higher degrees of protection of up to IP64 can be achieved and a tensile load of up to 60 N (13 lbf) can be exerted on the cable.

Miniature safety edge (without control unit)	SK EKS/W 014 TPE or SK EKS/BK 014 TPE
Testing basis	In accordance with ISO 13856-2
Sensor colour	Black
Switching characteristics at $v_{test} = 50 \text{ mm/min}$ (2 in/min)	
Switching operations	10,000
Actuation force	+23 °C (+73.4 °F) -25 °C (-13 °F)
Test piece (rod) Ø 4 mm (5/32")	< 15 N (3.3 lbf) < 30 N (6.7 lbf)
Test piece (rod) Ø 200 mm (7 7/8")	< 25 N (5.6 lbf) < 50 N (11.2 lbf)
Actuation distance	
Test piece (cylinder) Ø 80 mm (3 5/32")	< 2.0 mm (5/64")
Actuation angle	
Test piece (cylinder) Ø 80 mm (3 5/32")	±40°
Finger detection	Yes
Safety classifications	
ISO 13849-1: B _{10D}	2x 10 ⁶
Mechanical operating conditions	
Sensor length (min. max.)	10 cm 50 m (4" 164')
Cable length	2.5 m (8')
Fixing method	Snap-in foot
Snap-in foot width	3.5 mm (9/64")
Aluminium profile (recommended)	C 10
Bend radii, minimum: B ₁ B ₂ B ₃ B ₄	120 150 20 20 mm (4 23/32" 5 29/32" 25/32" 25/32")
Max. load capacity (impulse)	600 N (134 lbf)
Tensile load, cable (max.)	20 N (4 lbf)
IEC 60529: degree of protection	IP40
Operating temperature	-25 to +80 °C (-13 to +176 °F)
Short-term (15 min)	-40 to +100 °C (-40 to +212 °F)
Storage temperature	-40 to +80 °C (-40 to +176 °F)
Weight: without with aluminium profile (type)	49 g/m 125 g/m (C 10) (0.53 oz/ft 1.35 oz/ft) (C 10)
Electrical operating conditions	
Terminal resistance (±1%)	1k2, 2k2, 5k6 or 8k2
Nominal output (max.)	250 mW
Resistance: sensor activated	< 400 ohms
Number of /BK-type sensors	Max. 3 in series
Switching voltage (max.)	DC 24 V
Switching current (min. max.)	1 10 mA
Connection cable	Ø 2.9 mm PVC 2x 0.25 mm ² (Ø 7/64" PVC 2x AWG24)

Technical data

SK EKS 052 TPE

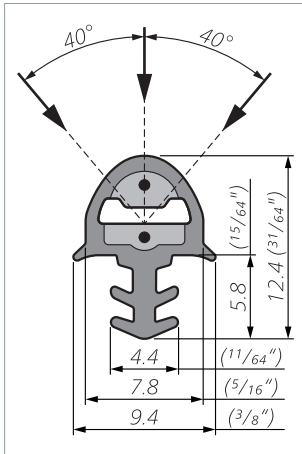

Dimensions in millimetres (mm)
Dimensional tolerances according to ISO 3302 E2/L2

Bend radii:

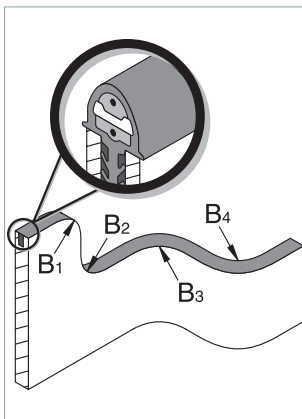

Higher degree of protection, higher tensile load

If special adhesive is used (e.g. Weicon VA 250 Black ID 10018873), higher degrees of protection of up to IP64 can be achieved and a tensile load of up to 60 N (13 lbf) can be exerted on the cable.

Miniature safety edge (without control unit)	SK EKS/W 052 TPE or SK EKS/BK 052 TPE
Testing basis	In accordance with ISO 13856-2
Sensor colour	Black, window grey (RAL 7040) or light grey (RAL 7035)
Switching characteristics at $v_{test} = 50 \text{ mm/min}$ (2 in/min)	
Switching operations	10,000
Actuation force	+23 °C (+73.4 °F) -25 °C (-13 °F)
Test piece (rod) Ø 4 mm (5/32")	< 25 N (5.6 lbf) < 30 N (6.7 lbf)
Test piece (rod) Ø 200 mm (7 7/8")	< 40 N (9.0 lbf) < 50 N (11.2 lbf)
Actuation distance	
Test piece (cylinder) Ø 80 mm (3 5/32")	< 2.0 mm (5/64")
Actuation angle	
Test piece (cylinder) Ø 80 mm (3 5/32")	±40°
Finger detection	Yes
Safety classifications	
ISO 13849-1: B _{10D}	2x 10 ⁶
Mechanical operating conditions	
Sensor length (min. max.)	10 cm 45 m (4" 147')
Cable length	2.5 m (8')
Fixing method	Clamp foot
Groove width for clamp foot	3.7 ±0.4 mm (9/64")
Bend radii, minimum: B ₁ B ₂ B ₃ B ₄	120 150 20 20 mm (4 23/32" 5 29/32" 25/32" 25/32")
Max. load capacity (impulse)	600 N (134 lbf)
Tensile load, cable (max.)	20 N (4 lbf)
IEC 60529: degree of protection	IP40
Operating temperature	-25 to +80 °C (-13 to +176 °F)
Short-term (15 min)	-40 to +100 °C (-40 to +212 °F)
Storage temperature	-40 to +80 °C (-40 to +176 °F)
Weight	54 g/m (0.58 oz/ft)
Electrical operating conditions	
Terminal resistance (±1%)	1k2, 2k2, 5k6 or 8k2
Nominal output (max.)	250 mW
Resistance: sensor activated	< 400 ohms
Number of /BK-type sensors	Max. 3 in series
Switching voltage (max.)	DC 24 V
Switching current (min. max.)	1 10 mA
Connection cable	Ø 2.9 mm PVC 2x 0.25 mm ² (Ø 7/64" PVC 2x AWG24)

Marking

If you combine sensors with control units and thereby place pressure-sensitive protective devices on the market, you should observe the basic requirements according to ISO 13856.

As well as meeting technical requirements, this also means – in particular – observing any that relate to marking and information for use.

UL certification



The design type of the product complies with the basic requirements of UL standard:

- UL 325

The same applies to all components listed in this document, with the exception of:

- 7504150 Contact profile EKS 052 TPE, window grey
- 11011768 Contact profile EKS 052 TPE, light grey
- 11008731 End piece with resistor 5k6
- 11008644 90° connector
- 1007219 End piece without resistor